

S-TEC

Pilot's Operating Handbook GPSS



| | | |
|--------------------------------|---|--------------------------------|
| List of Effective Pages | * Asterisk indicates pages changed, added, or deleted by current revision. | |
| | | |
| Record of Revisions | Retain this record in front of handbook. Upon receipt of a revision, insert changes and complete table below. | |
| Revision Number | Revision Date | Insertion Date/Initials |
| 1 st Ed. | Mar 14, 00 | |
| 2 nd Ed. | Dec 13, 00 | |
| 3 rd Ed. | Jan 14, 02 | |
| 4 th Ed. | Sep 05, 03 | |
| 5 th Ed. | Feb 15, 08 | |
| | | |
| | | |
| | | |
| | | |
| | | |
| | | |
| | | |
| | | |
| | | |
| | | |
| | | |
| | | |

Page Intentionally Blank

Table of Contents

| Sec. | | Pg. |
|------|--|-----|
| 1 | Overview..... | 1-1 |
| | 1.1 Document Organization..... | 1-3 |
| | 1.2 Purpose..... | 1-3 |
| | 1.3 General Control Theory..... | 1-3 |
| | 1.4 Block Diagram..... | 1-4 |
| 2 | Pre-Flight Procedures..... | 2-1 |
| | 2.1 Pre-Flight Test..... | 2-3 |
| 3 | In-Flight Procedures..... | 3-1 |
| | 3.1 Normal Operating Procedures..... | 3-3 |
| | 3.1.1 Heading (HDG) Mode..... | 3-3 |
| | 3.1.2 Global Positioning System Steering (GPSS) Mode..... | 3-3 |
| | 3.2 Approach Procedures..... | 3-4 |
| | 3.2.1 Standard Approach..... | 3-4 |
| | 3.2.2 GPS Overlay of VOR / DME-A Approach..... | 3-4 |
| | 3.2.3 GPS-T Approach..... | 3-4 |
| | 3.2.4 GPS Approach with Holding Pattern..... | 3-4 |
| | 3.2.5 GPS Overlay of VOR Approach with Procedure Turn..... | 3-4 |
| | 3.3 Emergency Procedures..... | 3-9 |
| 4 | Operating Parameters..... | 4-1 |
| | 4.1 Ranges..... | 4-3 |
| 5 | Glossary..... | 5-1 |

List of Figures

| Fig. | | Pg. |
|-------------|--|------------|
| 1-1 | HDG / GPSS Selector Switch..... | 1-5 |
| 1-2 | ST-901 GPSS Converter Block Diagram..... | 1-5 |
| 2-1 | HDG / GPSS Selector Switch (Pre-Flight)..... | 2-4 |
| 3-1 | GPS Overlay of VOR / DME-AAApproach..... | 3-5 |
| 3-2 | GPS-T Approach..... | 3-6 |
| 3-3 | GPS Approach with Holding Pattern..... | 3-7 |
| 3-4 | GPS Overlay of VOR Approach with Procedure Turn..... | 3-8 |

List of Tables

| Table | | Pg. |
|--------------|----------------------|------------|
| 2-1 | Pre-Flight Test..... | 2-3 |

SECTION 1 OVERVIEW

Page Intentionally Blank

1.1 Document Organization

Section 1 Overview

Section 2 Pre-Flight Procedures

Section 3 In-Flight Procedures

Section 4 Operating Parameters

Section 5 Glossary

1.2 Purpose

This Pilot's Operating Handbook (POH) provides Pre-Flight and In-Flight operating procedures for the S-TEC ST-901 Global Positioning System Steering (GPSS) Converter.

Note:

This POH must be carried in the A/C and made available to the pilot at all times. It can only be used in conjunction with the Federal Aviation Administration (FAA) approved Aircraft Flight Manual (AFM) or Aircraft Flight Manual Supplement (AFMS). Refer to the applicable AFM or AFMS for A/C specific information, such as unique ground tests, limitations, and emergency procedures.

Note:

The GPSS Converter is a tool provided to aircraft owners, that serves to assist them with cockpit workload management. The ability of the GPSS Converter to provide optimum assistance and performance is directly proportional to the pilot's knowledge of its operating procedures. Therefore, it is highly recommended that the pilot develop a thorough understanding of the GPSS Converter and its operating procedures in Visual Meteorological Conditions (VMC), prior to using it under Instrument Flight Rules (IFR).

1.3 General Control Theory

The GPSS Converter can be used with the following S-TEC autopilots:

System Twenty / Thirty

System Forty / Fifty

System Fifty Five

System Sixty Two

System Sixty Five

S-TEC

It has the following modes of operation:

HDG Mode - Used to turn onto a Selected Heading and Hold it

GPSS Mode - Used to Laterally Steer along a Course defined by Waypoints, that have been programmed into the GPS Navigator

Pressing the HDG / GPSS Selector Switch will alternately engage the HDG mode and GPSS mode. This switch is shown in Fig. 1-1. As indicated, when the HDG mode is engaged, the HDG lamp is illuminated and the GPSS lamp is extinguished, but when the GPSS mode is engaged, the GPSS lamp is illuminated and the HDG lamp is extinguished.

The GPSS Converter is internally configured to be compatible with the particular AC or DC Heading System installed in the aircraft, be it a Directional Gyro (DG) or Horizontal Situation Indicator (HSI). The output of the Heading System will be either an AC or DC Heading Error Signal. When the GPSS Converter's HDG mode is engaged, the GPSS Converter processes the AC or DC Heading Error Signal at its input, to produce a proportional DC Heading Error Signal at its output. This signal is sent to the input of the autopilot's heading error channel. When the autopilot's HDG mode is also engaged, the autopilot will turn the aircraft onto the selected heading and hold it.

The GPS Navigator is programmed with a sequence of waypoints, as a means to define a course. This course is realized at the output of the GPS Navigator in the form of two digital signals, the Bank Angle Signal and Ground Speed Signal. When the GPSS Converter's GPSS mode is engaged, the GPSS Converter processes the Bank Angle Signal and Ground Speed Signal at its input, to produce a DC Turn Rate Signal at its output. This signal is sent to the input of the autopilot's heading error channel. When the autopilot's HDG mode is also engaged, the autopilot will laterally steer the aircraft along the course defined by the waypoints.

1.4 Block Diagram

The GPSS Converter Block Diagram is shown in Fig. 1-2.



Fig. 1-1. HDG / GPSS Selector Switch

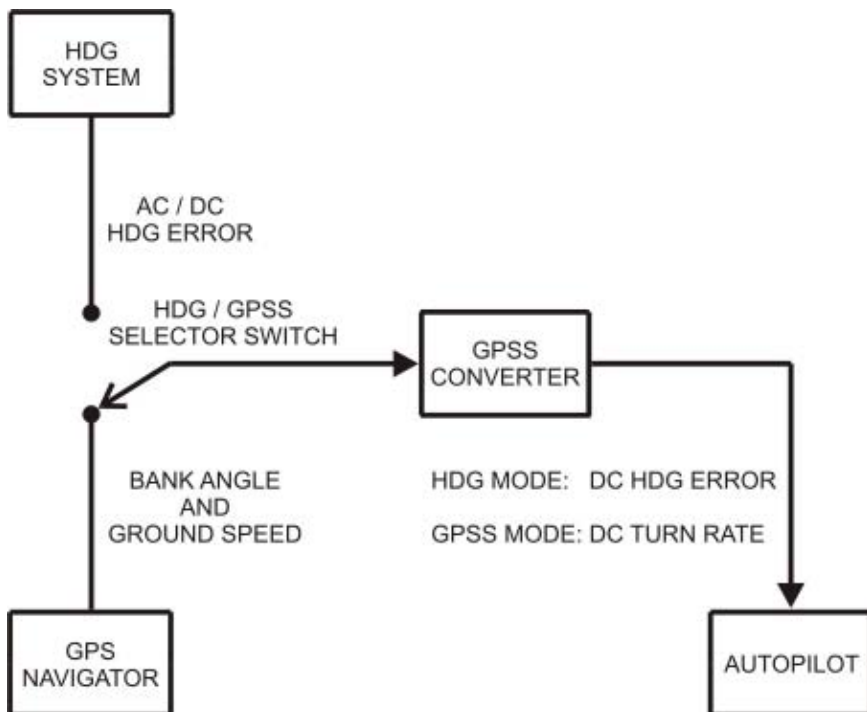

Fig. 1-2. ST-901 GPSS Converter Block Diagram

Page Intentionally Blank

SECTION 2 PRE-FLIGHT PROCEDURES

Page Intentionally Blank

2.1 Pre-Flight Test

Prior to takeoff and with engine running, perform the actions shown in Table 2-1. For each action, verify the corresponding response where applicable.

Table 2-1. Pre-Flight Test (continued on page 2-4)

| ACTION | RESPONSE |
|---|--|
| 1. Set Battery Master Switch to ON position. | ----- |
| 2. Set Avionics Master Switch to ON position. | ----- |
| 3. Set Autopilot Master Switch to ON position. | HDG lamp is illuminated and GPSS lamp is extinguished on HDG / GPSS Selector Switch, as an indication that GPSS Converter's HDG mode is engaged. This is shown in Fig. 2-1a. |
| 4. Set Heading Bug under Lubber Line. | ----- |
| 5. Engage autopilot's HDG mode. | ----- |
| 6. Turn Heading Bug to the left side of Lubber Line. | A/C Control Wheel turns to the left. |
| 7. Turn Heading Bug to the right side of Lubber Line. | A/C Control Wheel turns to the right. |
| 8. Set Heading Bug under Lubber Line. | A/C Control Wheel stops. |
| 9. Program GPS Navigator with a valid waypoint. | ----- |

Table 2-1. Pre-Flight Test (continued from page 2-3)

| ACTION | RESPONSE |
|--|---|
| 10. Press HDG / GPSS Selector Switch. | GPSS lamp is illuminated and HDG lamp is extinguished on HDG / GPSS Selector Switch, as an indication that GPSS Converter's GPSS mode is engaged. This is shown in Fig. 2-1b. |
| 11. Turn Heading Bug to the left side and right side of Lubber Line. | A/C Control Wheel does not respond. |
| <i>Note: The GPSS mode cannot be tested since there is no groundspeed.</i> | |
| 12. Disconnect autopilot. | ----- |



a. HDG Mode Engaged



b. GPSS Mode Engaged

Fig. 2-1. HDG / GPSS Selector Switch

SECTION 3 IN-FLIGHT PROCEDURES

Page Intentionally Blank

3.1 Normal Operating Procedures

3.1.1 Heading (HDG) Mode

Set the Heading Bug to the desired heading on the compass card (HSI or DG).

Engage the GPSS Converter's HDG mode.

Engage the autopilot's HDG mode.

The autopilot will turn the aircraft onto the selected heading and hold it. The turn rate will be limited to 90% of a standard rate turn, although for some higher performance (turboprop) aircraft this is 75%.

A new heading can be subsequently selected by setting the Heading Bug to it.

3.1.2 Global Positioning System Steering (GPSS) Mode

Set the Heading Bug under the Lubber Line.

Engage the GPSS Converter's HDG mode.

Engage the autopilot's HDG mode.

Program the GPS Navigator with a sequence of waypoints, as a means to define the desired course.

Engage the GPSS Converter's GPSS mode.

The autopilot will begin to laterally steer the aircraft along the course (i.e., track the course).

The turn rate will be limited to 90% of a standard rate turn, although for some higher performance (turboprop) aircraft this is 75%.

If it should happen that the GPS Navigator has not been programmed with a sequence of waypoints upon attempted engagement of the GPSS mode, then the autopilot will hold the aircraft at wings level, and the GPSS lamp will flash on the HDG / GPSS Selector Switch to acknowledge this condition.

Engaging any autopilot roll mode other than HDG (i.e., NAV, APR, REV, STB, LO TRK, HI TRK) will decouple the autopilot from the GPSS mode.

With the GPSS mode engaged, the autopilot will not respond to the Heading Bug or Course Pointer.

Note:

It is not possible to simultaneously engage the HDG mode and arm the GPSS mode. Consequently, there does not exist the capability to execute a dual mode, pilot selectable intercept angle of the course.

3.2 Approach Procedures

3.2.1 Standard Approach

Set the Heading Bug under the Lubber Line.

Engage the GPSS Converter's HDG mode.

Engage the autopilot's HDG mode.

Program the GPS Navigator with the desired approach.

Engage the GPSS Converter's GPSS mode.

The autopilot will begin tracking to the Initial Approach Fix (IAF).

To execute any required procedure turn or holding pattern, proceed as follows:

1. Engage the GPSS Converter's HDG mode.
2. Lead the aircraft around the procedure turn or holding pattern using the Heading Bug.
3. Once established on the inbound course, engage the GPSS Converter's GPSS mode.
4. Complete the approach.

3.2.2 GPS Overlay of VOR / DME-A Approach

Refer to Fig. 3-1.

3.2.3 GPS-T Approach

Refer to Fig. 3-2.

3.2.4 GPS Approach with Holding Pattern

Refer to Fig. 3-3.

3.2.5 GPS Overlay of VOR Approach with Procedure Turn

Refer to Fig. 3-4.

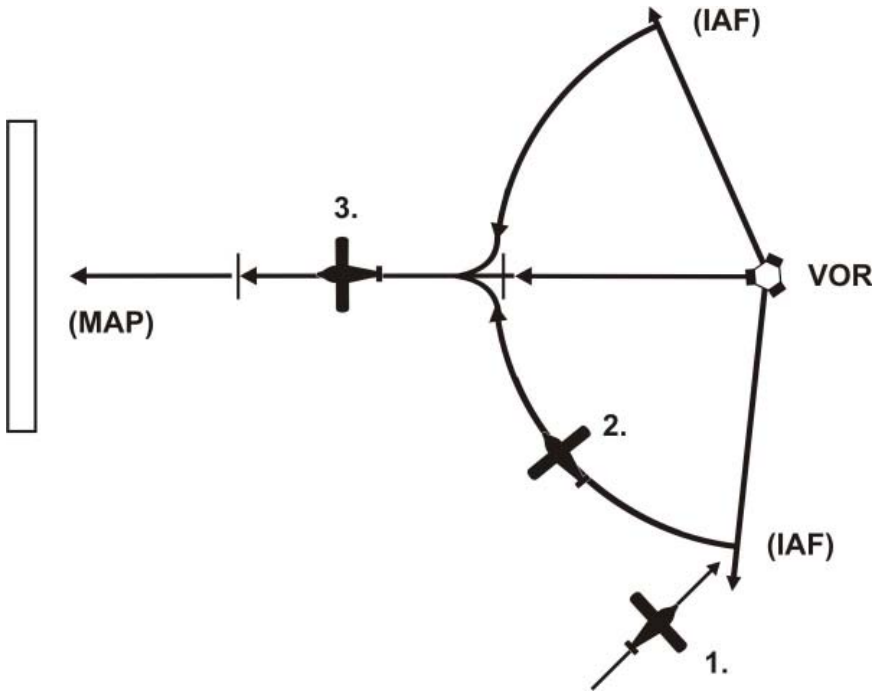

1. a. Set the Heading Bug under the Lubber Line.
 b. Engage the GPSS Converter's HDG mode.
 c. Engage the autopilot's HDG mode.
 d. Program the GPS Navigator with the desired approach.
 e. Engage the GPSS Converter's GPSS mode.
 f. The autopilot begins tracking to the Initial Approach Fix (IAF).
2. a. The autopilot intercepts the IAF, and then tracks around the arc.
3. a. The autopilot becomes established on the inbound course.
 b. At the Missed Approach Point (MAP), disconnect the autopilot for a landing or go-around, as required.

Fig. 3-1. GPS Overlay of VOR / DME-A Approach

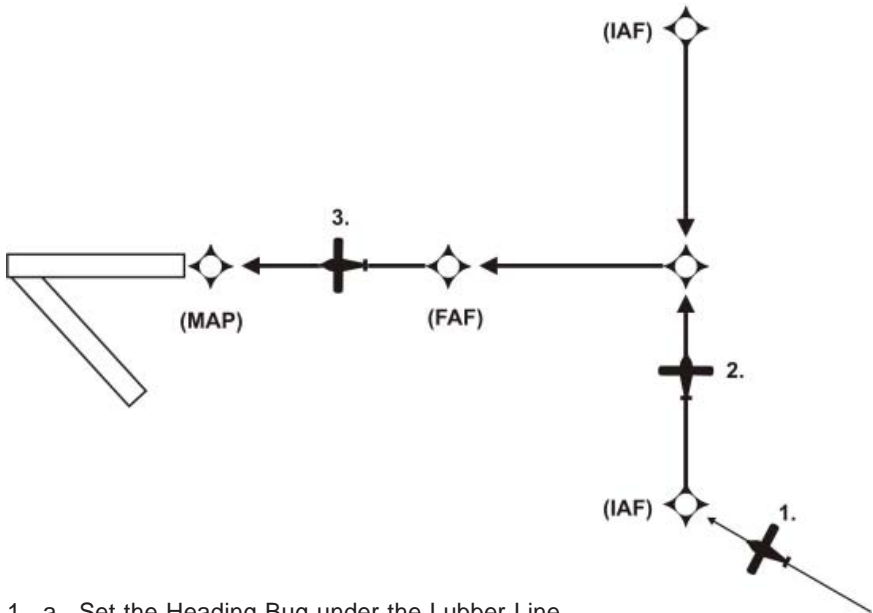

1.
 - a. Set the Heading Bug under the Lubber Line.
 - b. Engage the GPSS Converter's HDG mode.
 - c. Engage the autopilot's HDG mode.
 - d. Program the GPS Navigator with the desired approach.
 - e. Engage the GPSS Converter's GPSS mode.
 - f. The autopilot begins tracking to the Initial Approach Fix (IAF).
2.
 - a. The autopilot intercepts the IAF, then makes a 90° turn, and begins tracking to the Final Approach Fix (FAF).
3.
 - a. The autopilot becomes established on the inbound course.
 - b. At the Missed Approach Point (MAP), disconnect the autopilot for a landing or go-around, as required.

Fig. 3-2. GPS-T Approach

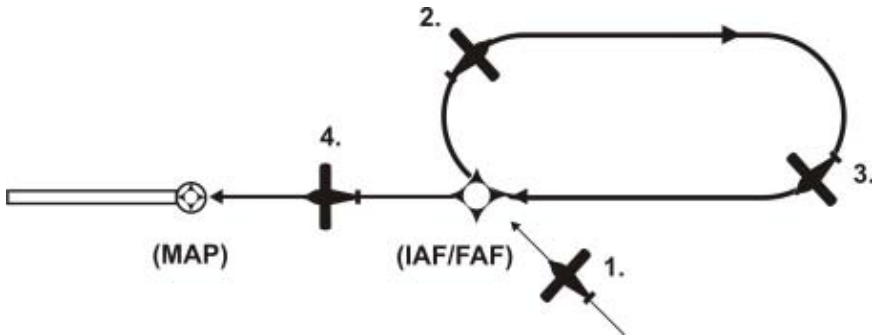

1. a. Set the Heading Bug under the Lubber Line.
 - b. Engage the GPSS Converter's HDG mode.
 - c. Engage the autopilot's HDG mode.
 - d. Program the GPS Navigator with the desired approach.
 - e. Engage the GPSS Converter's GPSS mode.
 - f. The autopilot begins tracking to the Initial Approach Fix (IAF).

Note:

Perform steps 2-3 only for those GPS Navigators that do not have the capability to execute a holding pattern.

2. a. Engage the GPSS Converter's HDG mode.
 - b. Lead the aircraft around the outbound leg of the holding pattern in 90° increments, using the Heading Bug.
3. a. Engage the GPSS Converter's GPSS mode.
 - b. The autopilot begins tracking to the Final Approach Fix (FAF).
4. a. The autopilot becomes established on the inbound course.
 - b. At the Missed Approach Point (MAP), disconnect the autopilot for a landing or go-around, as required.

Fig. 3-3. GPS Approach with Holding Pattern

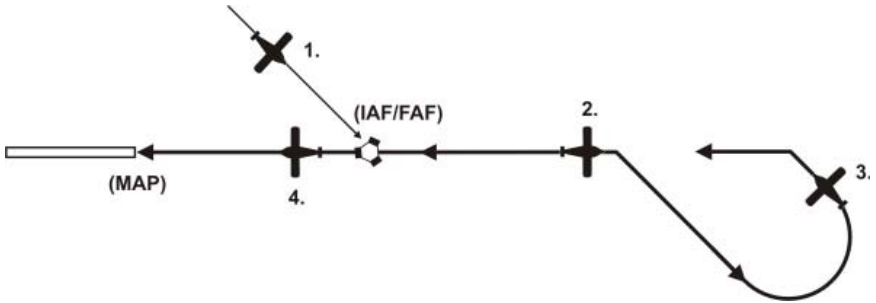

1. a. Set the Heading Bug under the Lubber Line.
- b. Engage the GPSS Converter's HDG mode.
- c. Engage the autopilot's HDG mode.
- d. Program the GPS Navigator with the desired approach.
- e. Engage the GPSS Converter's GPSS mode.
- f. The autopilot begins tracking to the Initial Approach Fix (IAF).

Note:

Perform steps 2-3 only for those GPS Navigators that do not have the capability to execute a procedure turn.

2. a. Engage the GPSS Converter's HDG mode.
- b. Lead the aircraft around the procedure turn in 90° increments, using the Heading Bug.
3. a. Engage the GPSS Converter's GPSS mode.
- b. The autopilot begins tracking to the Final Approach Fix (FAF).
4. a. The autopilot becomes established on the inbound course.
- b. At the Missed Approach Point (MAP), disconnect the autopilot for a landing or go-around, as required.

Fig. 3-4. GPS Overlay of VOR Approach with Procedure Turn

3.3 Emergency Procedures

In the event of a GPSS Converter malfunction, proceed as follows:

1. Disconnect the autopilot.
2. Regain control of the aircraft.
3. **Do Not** attempt to use the GPSS Converter's HDG mode or GPSS mode.
4. **Do Not** attempt to use the autopilot's HDG mode.

Note:

It may be possible to use other autopilot roll modes (i.e., NAV, APR, REV, STB, LO TRK, HI TRK).

Page Intentionally Blank

SECTION 4 OPERATING PARAMETERS

Page Intentionally Blank

4.1 Roll Axis Limits

Turn Rate

Piston A/C:

90% Standard Rate Turn

Turboprop A/C:

75% Standard Rate Turn

Page Intentionally Blank

SECTION 5 GLOSSARY

Page Intentionally Blank

| Term | Meaning |
|-------------|---|
| AC | Alternating Current |
| A/C | Aircraft |
| AFM | Aircraft Flight Manual |
| AFMS | Aircraft Flight Manual Supplement |
| APR | Approach |
| DC | Direct Current |
| DG | Directional Gyro |
| DME | Distance Measuring Equipment |
| FAA | Federal Aviation Administration |
| FAF | Final Approach Fix |
| GPS | Global Positioning System |
| GPSS | Global Positioning System Steering |
| HDG | Heading |
| HI TRK | High Track |
| HSI | Horizontal Situation Indicator |
| IAF | Initial Approach Fix |
| IFR | Instrument Flight Rules |
| LO TRK | Low Track |
| MAP | Missed Approach Point |
| NAV | Navigation |
| POH | Pilot's Operating Handbook |
| REV | Reverse |
| STB | Stabilizer |
| VMC | Visual Meteorological Conditions |
| VOR | Very High Frequency Omnidirectional Radio Range |

Page Intentionally Blank

S-TEC

Information contained in this document is subject to change without notice. © 2008 S-TEC. All rights reserved. Printed in the United States of America. S-TEC and the S-TEC logo are registered trademarks of S-TEC.

Notice:

Contact S-TEC Customer Support at 800-872-7832 for a Return Material Authorization (RMA) number prior to the return of any component for any reason.

**One S-TEC Way
Municipal Airport
Mineral Wells, TX 76067-9236
Tel: 800-872-7832
Fax: 940-325-3904
www.s-tec.com
S-TEC PN 8799**